

KENDALL COUNTY HEALTH DEPARTMENT

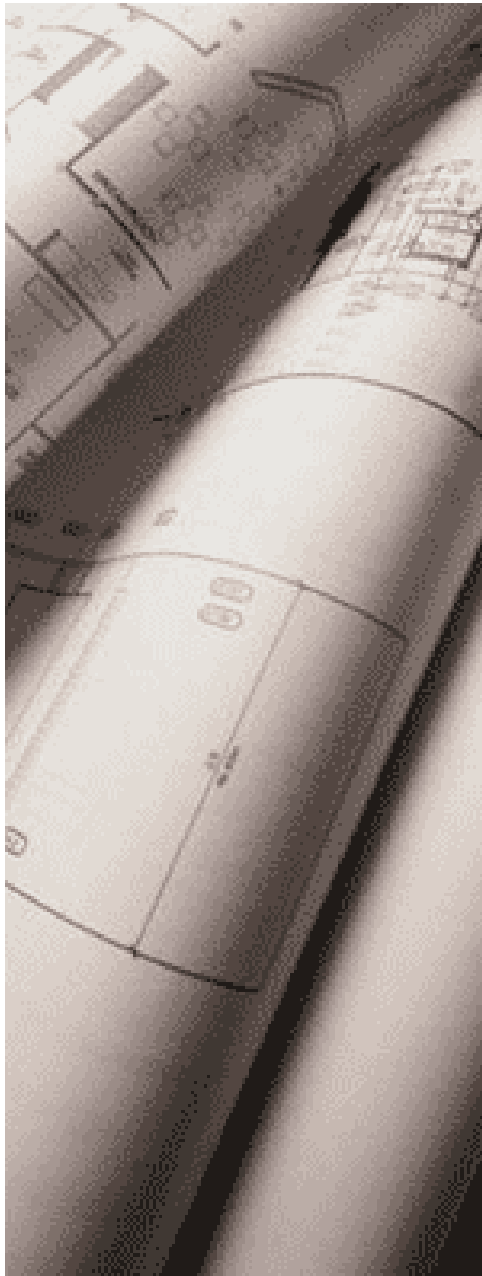

FOOD SERVICE ESTABLISHMENT CONSTRUCTION GUIDE

Environmental Health Unit
811 West John Street
Yorkville, IL 60560
(630) 553-9100 ext. 8026
Fax: (630) 553-9603
www.kendallhealth.org

Introduction

This guide is for architects, building contractors, food service equipment dealers, food service operators, consultants and other interested professionals. The purpose of this manual is to help in the development of plans to meet the standards of the Kendall County Health Department. Our goal is to provide you with helpful information that will enable you to design the best food service facility possible.

Local municipalities have building, zoning, mechanical, electrical, plumbing and fire protection requirements. You will need to contact these other agencies prior to construction for information on their regulations and for approval to commence with construction.

The purpose of our plan review is twofold. First, the plan review will help to eliminate complications in your establishment's design, subsequent construction schedules, and final approval before opening for business. Second, the Kendall County Food Establishment Sanitation Ordinance requires a plan review for the construction or remodel of, or conversion of a building to, a food service establishment. Our objective is for you to create a food service establishment that is easy to maintain, has efficient food flow patterns, and is set up to handle the maximum number of customers.

The layout and design of the plans are based on HACCP (Hazard Analysis Critical Control Point) quality assurance concepts. A menu analysis, based on risk assessment, is part of the plan review process. **Submit your menu with your plans for approval.** The type and variety of foods served will influence the type of equipment required. Consider the steps you will use to produce the foods on your menu. This will aid in providing equipment best suited for your operation.

Some important points to remember:

- ⇒ Anticipate your equipment needs to meet food storage, preparation, holding and serving demands.
- ⇒ Install the equipment to be easily accessible for cleaning.
- ⇒ Develop an efficient food flow, from the point of delivery to final service.

Should you have any questions during the planning or construction process, please contact: Kendall County Health Department, Environmental Health at (630) 553-9100 ext. 8026.

Contents

I.	Plans, Inspections and Fees.....	5
	A. Plan Review.....	5
	B. Inspections.....	5
	C. Fees.....	5
II.	Equipment.....	7
	A. Materials and Design.....	7
	B. Specialty Equipment.....	7
	C. Equipment Installation Directions.....	9
III.	Refrigeration	
	General Storage.....	11
	A. Walk-In Coolers.....	12
	B. Reach-In Refrigerators.....	12
	C. Freezers.....	12
	D. Blast Chillers.....	12
	E. Refrigerated Worktables.....	12
	F. Refrigeration Processing Rooms.....	12
	G. Display Storage Refrigerators.....	12
	H. Customer Self-Service Display Refrigerators and Freezers.....	12
	I. Cold Buffet Units.....	13
	J. Ice Machines.....	13
IV.	Storage.....	13
	A. Dry Storage Area.....	13
	B. Storage Locations.....	13
	C. Shelving.....	14
V.	Employee Areas, Restrooms and Hand Washing Sinks.....	15
	A. Employee Area.....	15
	B. Restrooms.....	15
	C. Hand Washing Sinks.....	16
VI.	Plumbing.....	17
	A. Water Supply.....	17
	B. Sewage Disposal.....	17
	C. Grease Interceptors.....	17
	D. Janitorial Sinks.....	18
	E. Overhead Sewer Lines.....	18
	F. Potable Water Backflow Protection.....	18
	G. Indirect Waste Connections.....	19
	H. Floor Drains.....	19
VII.	Sanitizing Equipment.....	21
	A. Hot Water System.....	21
	B. Manual Utensil Washing.....	21
	C. Mechanical Utensil Washing.....	22

VIII. Lighting.....	23
A. Food Service Areas.....	23
B. Walk-In Refrigerators and Freezers.....	23
C. Storage and Restrooms.....	23
D. Bars.....	24
E. Protection Against Breakage.....	24
IX. Laundry.....	24
A. Location.....	24
B. Clothes Dryer.....	24
C. Linens.....	24
X. Room and Area Finishes.....	24
A. Food Preparation and Food Storage Areas.....	24
B. Cook line.....	25
C. Utensil Washing and Janitorial Station Areas.....	25
D. Walk-In Refrigerator or Freezer Units.....	25
E. Server, Pick-Up or Wait Stations.....	26
F. Bar.....	26
G. Restrooms, Dressing and Locker Rooms.....	26
H. Dining Rooms.....	27
I. Buffets, Salad Bars and Beverage Stations.....	27
J. Areas with Multiple Uses.....	27
K. Summary of Room and Area Finishes.....	28
XI. Insect and Rodent Control.....	30
A. Building.....	30
B. Delivery Doors.....	30
C. Windows.....	30
XII. Garbage and Refuse.....	31
A. Garbage Containers.....	31
B. Garbage Area.....	31
XIII. Exhaust Hood Ventilation for Cookline Equipment.....	32
A. Exhaust Plans Submittal.....	32
B. When Exhaust Hoods Are Required.....	32
C. Size of the Exhaust Hood.....	33
D. Exhaust Ducts.....	33
E. Exhaust Filter.....	33
F. Exhaust Fan.....	34
G. Make-Up Air.....	34
H. Construction and Criteria Checklist.....	35
Index.....	36

I. Plans, Inspections and Fees

A. Plan Review

Your plans must receive approval from this Department before you begin constructing, enlarging, altering or converting any building for use as a restaurant, tavern or food service facility. Provide a completed Food Service Establishment Plan Review Application, and one set of detailed plans drawn to scale.

Include with your plans:

1. Food service equipment specifications with manufacturers' names and model numbers. You should also include equipment specification sheets.
2. Floor plans and food service equipment layouts. Refer to Figure 1 on the following page. We may ask for equipment elevations if they are not shown on specification sheets.
3. Plumbing plans and layouts.
4. Room and area finish schedules for floors, coved surfaces, walls, doors and ceilings.
5. Mechanical kitchen ventilation exhaust plans.
6. A copy of your menu.

Plans that are incomplete will not receive approval.

If you want to make any changes after this Department has approved the plans, you must submit those changes in writing and receive written approval before construction. If the changes to the originally approved plans are extensive, you may be charged an additional plan review fee.

B. Inspections

During construction, the Kendall County Health Department will make inspections of your facility's construction and the installation of your equipment.

A pre-opening inspection and a construction final inspection are required. You may arrange these inspections, and additional inspections or field consultations, by calling the Environmental Health Unit of the Kendall County Health Department. We will issue a permit to the business owner after you have completed these steps and demonstrated compliance with applicable state and local codes.

C. Fees

Include with your application the appropriate plan review fee* payable to Kendall County Health Department. Churches and units of government may request a reduction of the plan review fee in writing, to be submitted to the Director of Environmental Health.

*See page 2 of the accompanying Food Service Establishment Plan Review Application for an explanation of Risk Categories and the fee schedule.

Figure 1: Partial Kitchen Layout

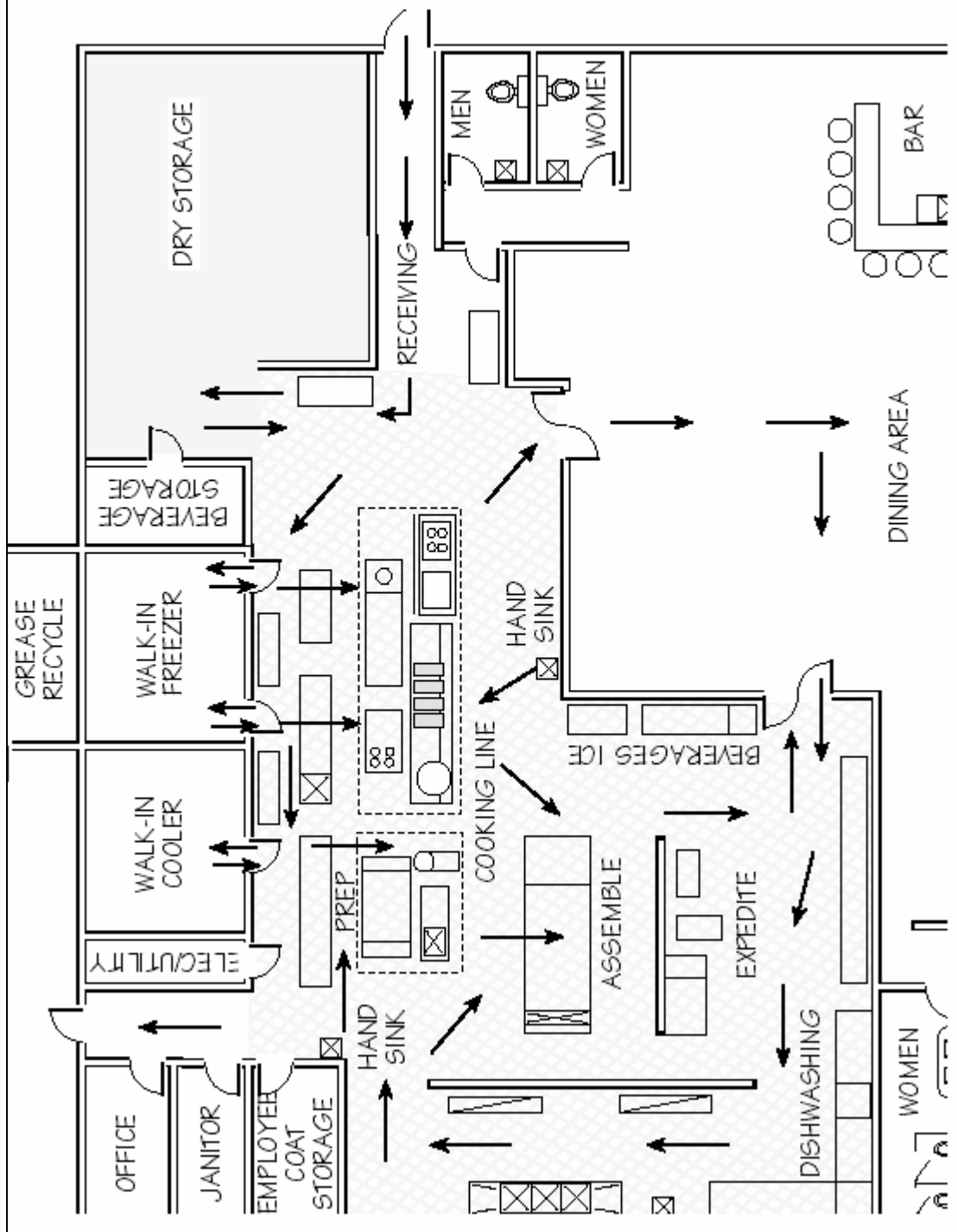

II. Equipment

A. Materials and Design

All food service equipment is to be commercial grade and meet the standards regarding design, materials and workmanship of the National Sanitation Foundation International (NSF), Underwriter's Laboratory Sanitation (UL Sanitation), or American Institute of Baking (AIB). An NSF or other recognized testing agency seal is usually a good indicator that the equipment is approved. Unmarked equipment may not meet the standards. Include make and model numbers on your plans so that equipment approval can be verified.

B. Specialty Equipment

1. Cold Plates: When installed in ice bins, the cold plates must be an integral part of the bin. Drop-in cold plates are not allowed. Refer to Figure 2 below.

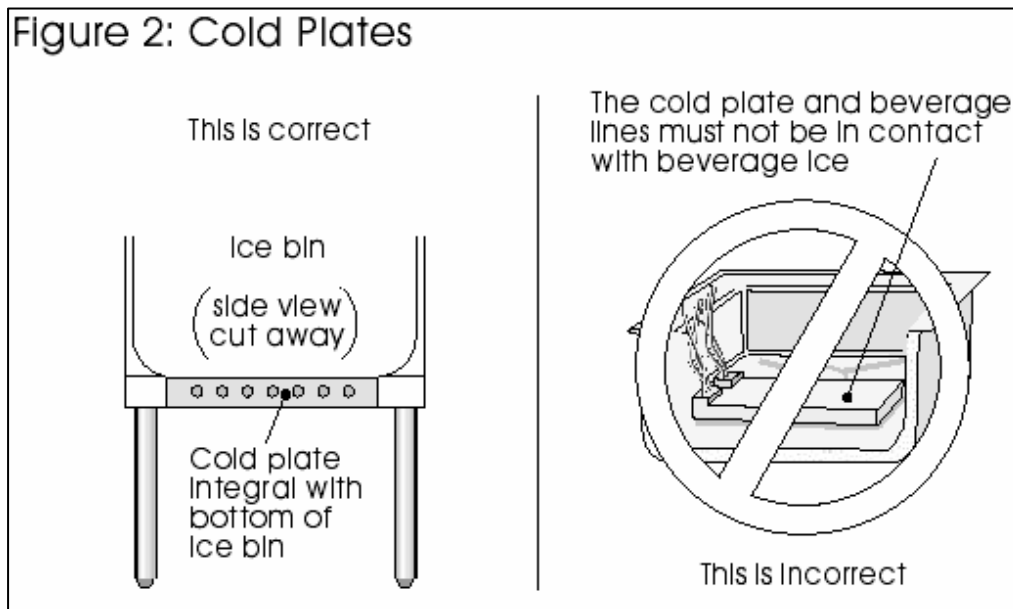

2. Dipper Wells: Provide dipper wells with running water where you dispense bulk ice cream. Also consider using dipper wells with dispensing utensils for other bulk foods such as cooked rice, whipped butter, etc. If the establishment will serve ice cream with known allergens (i.e. tree nuts, etc.), it is highly recommended that 2 separate dipper wells are provided to prevent cross contamination and resulting allergic reactions.
3. Food Preparation Sink: Install a separate sink with an integral drainboard designed for vegetable washing or food preparation only in the food preparation area. Options to be considered are multiple compartments and overhead spray faucets.
4. Single Service Dispensing Equipment: Install equipment for properly handling single service items like paper cups, lids and straws.
5. Food Contact Surfaces: Install work surfaces made of stainless steel or solid surface material like Corian®. NSF approved cutting surfaces are acceptable where food is prepared and assembled. They must be durable under conditions of normal use and cleaning.

6. Cheese Melters: When installed, these must be under an exhaust ventilation system, and over non-cooking equipment or low heat producing equipment. If you install the cheese melter over cooking equipment, you must install an angled or coved deflector that completely encloses the bottom and sides of the cheese melter. The deflector must direct vapor and hot gases toward the front of the cheese melter. The deflector must be constructed of stainless steel. Refer to Figure 3 below.

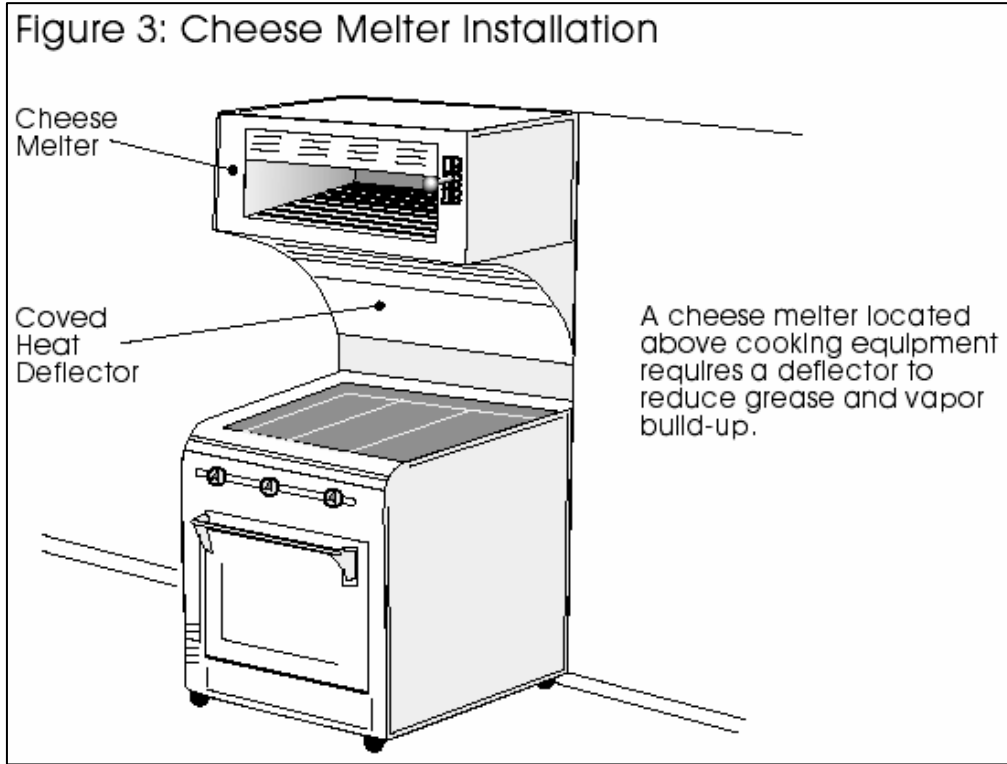

7. Buffets

- a. Open Food Display: Protect food on display from consumer contamination by using easily cleanable sneeze shields, display cases and similar equipment. Design and install these devices to intercept a direct line between a customer's mouth and foods on display. Submit a scaled drawing of this equipment to this Department for approval. Refer to Figure 4 below.

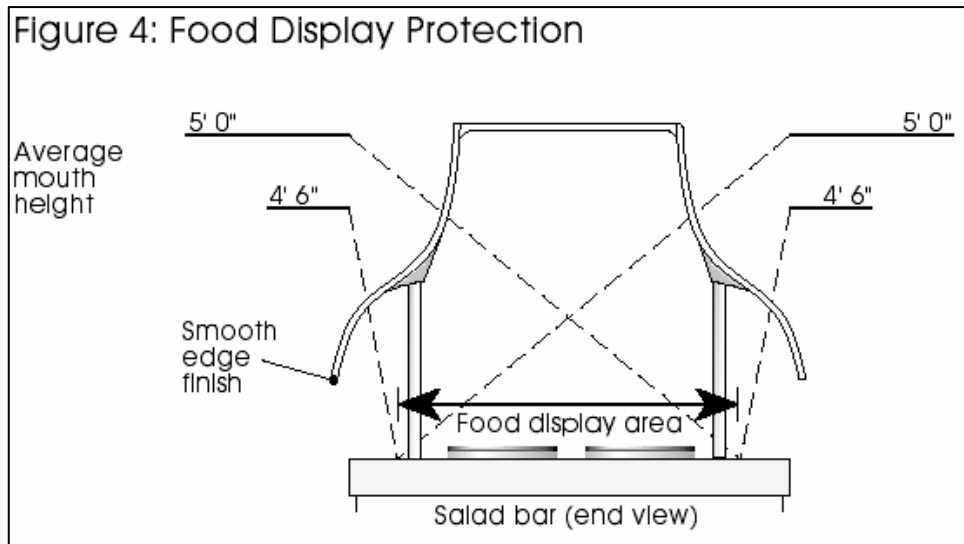

- b. Temperature Control: Provide equipment to maintain all perishable and potentially hazardous foods at required temperatures. Provide thermometers in all hot and cold food holding units.

8. Drive-thru and walk up windows

- a. Exterior food pass-thru drawers are required to be fitted with removable pans having seamless covered corners.
- b. Exterior food pass-thru windows:
 1. Must have smooth and easily cleanable counter surfaces.
 2. Must have open-ended window slide channels for cleanability.
 3. Must be provided with a self-closing device.

C. Equipment and Installation Directions

1. Table-Mounted Equipment: Install table-mounted equipment on 4 inch legs, unless it is portable. Portable equipment weighs less than 75 pounds and has no rigid utility connections. Keep pieces of table-mounted equipment at least 6 inches apart to ensure access for cleaning.
2. Floor-Mounted Equipment: Install floor-mounted equipment using method a, b or c:
 - a. Casters: The preferred method of installation is to put equipment on casters. Use coated steel, commercial-grade utility connections that are smooth and flexible with quick disconnects. They must meet NSF standards. Connections must be long enough to move the equipment so the area around and behind can be cleaned. When you cannot meet other equipment spacing criteria, you must mount the equipment on casters. Refer to Figure 5 on the following page.

Tip: For long equipment banks, consider integrating moveable equipment on casters with stationary equipment on legs for cleaning and servicing access.

- b. Spacing: Install equipment, other than portable equipment, with sufficient space between the adjacent equipment, floors, walls, cabinets and ceilings to facilitate proper cleaning. Floor-mounted equipment that you plan to install on legs must have a minimum floor clearance of 6 inches. Measure this clearance from the lowest obstruction under the piece of equipment (i.e., drain lines, water lines, electric lines, etc.). The equipment's dimensions determine the space needed for cleaning access.
 1. Maintain a minimum of 8 inches of spacing when the area to be cleaned is less than 4 feet long.
 2. Maintain a minimum of 18 inches of spacing when the area to be cleaned is 4 feet or longer.
- c. Sealing: Use 100 percent silicone sealant or cleanable trim to seal spaces. This includes spaces between non-portable equipment; accesses to cabinet voids, around pipes, around wall mounted equipment, etc. The silicone bead must be smooth and covered (3/8 inch radius). Avoid excessive application in large gaps. Refer to Figure 6 on the following page.

Figure 5: Comparing Caster & Leg Installation Methods

Fryers on casters take up less floor space and are easier to clean.

Equipment that you can roll on casters has no lateral spacing requirements from the wall.

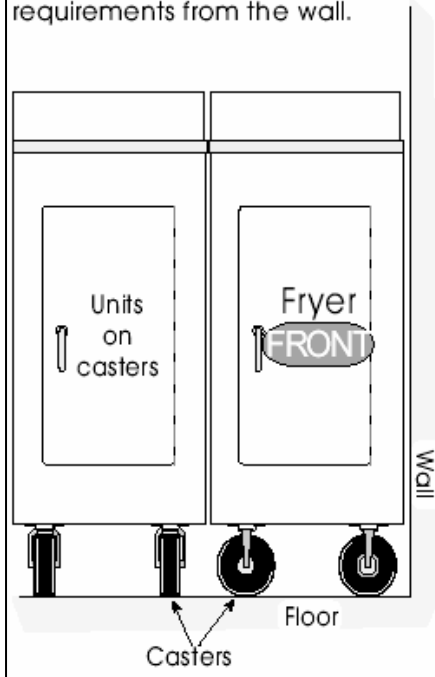

Fryers on legs must meet minimum spacing requirements, according to their size.

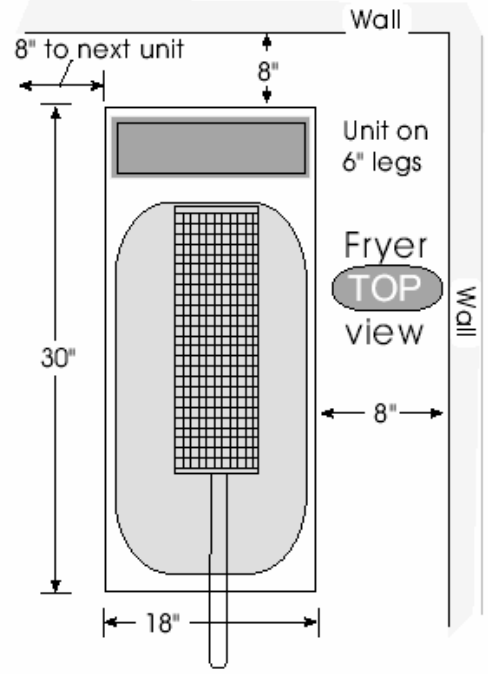
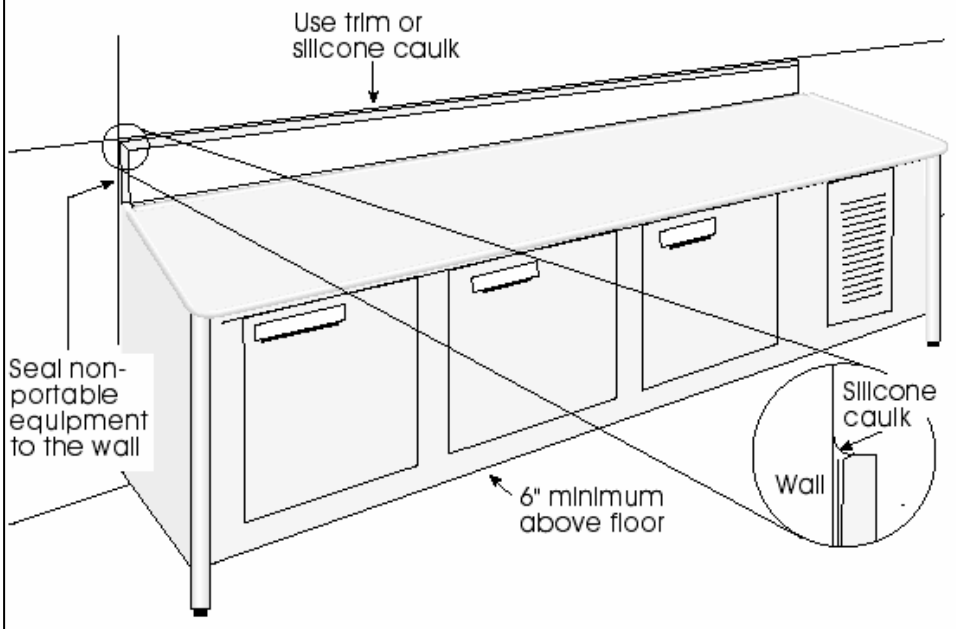

Figure 6: Sealing in Place



- d. Seal cabinet, flooring and wall interfaces that are larger than 1/32 inch and smaller than 6 inches. Seal all gaps, voids and protrusions using silicone sealant or trim that meets the finish material standards.
 - e. While allowed by code, raised floor platforms are not a recommended method of food service equipment installation.
3. Conduits: Keep all exposed utility lines (plumbing, gas, electrical, refrigeration, etc.) to a minimum. Keep exposed lines at least 6 inches off the floor, and at least 1/2 inch away from walls and ceilings.
 4. Walk-In coolers: Choose whether the space between the top of a walk-in cooler or freezer and the ceiling will be closed or open.
 - a. If closed, enclose the space with a panel (either fixed or removable).
 - b. If open, provide an unobstructed open space of at least 30 inches between the top of the unit and the ceiling. This area is not to be used as storage.

III. Refrigeration

General Storage

Refrigerators and freezers are required to maintain potentially hazardous foods below 41°F and 0°F respectively. These units must meet NSF design and material standards. Therefore, domestic-type refrigerators and freezers are not approved for retail food service.

Refrigeration and freezer storage involves six major areas.

1. Storage for short-term holding of perishable and potentially hazardous food items.
2. Freezer storage for long-term storage.
3. Storage space for quick chilling of foods.
4. Space for assembling and processing of potentially hazardous foods.
5. Display storage.
6. Display storage for customer self-service.

Calculating the amount of refrigeration and freezer space is based on the menu and the expected food volume. The amount and location of refrigeration and freezer equipment should complement the food flow of the operation from receiving, storage, and food processing to the point of service.

When assessing the refrigeration needs, consideration must be given to separate raw meats and poultry from ready-to-eat foods such as produce and pre-prepared food items. Thermometers must be conspicuously located in all units. Thermometer sensing elements should be located near the door(s). Additional measures such as high-temperature alarms should be installed when storing large quantities of potentially hazardous foods.

A. Walk-In Coolers

Walk-in coolers shall be installed when there is a need for long-term storage of perishable and potentially hazardous foods or when quick chilling space is needed for prepared and cooked foods. These coolers should be located near delivery or receiving areas.

Tip: When walk-in coolers are to be used for storage and to chill food quickly, it is recommended that portable racks be provided to help maximize usable floor space.

B. Reach-In Refrigerators

These units are for short-term storage of perishable and potentially hazardous foods. These units should be considered to meet the daily demands of the kitchen operation. They are to be conveniently located at points of food preparation and food assembly. These units are not to be considered for the quick chilling of cooked and prepared foods.

Tip: Locating refrigeration units under or adjacent to heat-generating pieces of equipment is not recommended.

C. Freezers

Freezers are for long-term storage. They are not designed to be used as quick-chill units. These units should be located near delivery and dry storage areas.

D. Blast Chillers

These units should be considered to handle large volumes of food that require quick chilling. A blast chiller is an efficient cooling mechanism for any amount of food to be chilled, and where refrigeration storage space is limited.

E. Refrigerated Worktables

These units are needed when the menu includes assembling potentially hazardous foods. These units provide easy access of foods from the top of the unit. These units are not designed for long-term storage or for quick chilling. All pan inserts must be stainless steel as stainless steel is a better conductor of cold than polycarbonate.

F. Refrigeration Processing Rooms

These areas shall be considered when there is extensive handling of cold potentially hazardous foods.

G. Display Storage Refrigerators

These units are designed to display potentially hazardous foods under refrigeration. Examples of these units are deli display, fresh fish display, fresh meat and poultry display cases.

H. Customer Self- Service Display Refrigerators and Freezers

These units are designed for holding foods under refrigeration for customer access. They are designed for short-term display and are not designed to quick-chill foods. Beverage display coolers are not approved for storing potentially hazardous foods.

I. Cold Buffet Units

Cold buffets and salad bars are designed for short-term display. They shall be mechanically refrigerated.

J. Ice Machines:

If ice is to be used as a cooling medium, the unit should be adequately designed and sized to meet all operational needs.

IV. Storage

A. Dry Storage Area

1. General: Provide suitable space on your plans for storing all food-related items. The minimum space required is 25 percent of all kitchen areas, based on wall-to-wall dimensions. Equip dry storage areas with adequate approved shelving. Storage space does not include floor areas where desks, equipment, ladders or other items may be placed. You should have an exterior door near the storage area so that delivery personnel do not have to walk through your food preparation area.
2. Installation: All shelving must be at least 6 inches above the floor. There must be at least 18 inches of clearance from the ceiling to the top of the items stored on shelving.
3. Liquor and Canned and Bottled Beverages: The storage space must be increased to a minimum of 35 percent of the total food service area for storage when liquor and beverages are a part of your operation.

B. Storage Locations

1. Cooking Utensils: Designate an area for clean cooking utensils, cutting boards, glassware and dishware. Store them on approved shelving in a clean, dry location where they will be protected from dust and splash.
2. Clean Linen: Provide a storage area for linens, if you use them. Protect clean linens from contamination, and store them away from soiled linens.
3. Soiled Linens: Specify the location of covered, non-absorbent containers or washable laundry bags designated for holding damp or soiled linens, soiled uniforms, aprons, etc.
4. Chemicals: Designate an area for toxic materials storage that is away from food and clean utensils. Install cages, cabinets or physically separated shelves for storing chemicals in each of the two following categories:
 - a. Pesticides approved for food service use: These must be in a secured cabinet.
 - b. Cleaners: These include detergents, sanitizers, related cleaning or drying agents and caustics, acids, polishes and other chemicals.

5. Maintenance Equipment: Designate an area for storing maintenance equipment and cleaning supplies. See Figure 7 below.

- a. Wall-Hung Storage: Specify adequate broom racks to keep brooms, dust pans, etc., off the floor.
- b. Mop Hooks: Install heavy-duty mop hooks that can support wet mops over the janitorial sink so that wet mops may drip dry into the sink basin.
- c. Shelving: Provide open wire or solid metal shelving at each janitorial station for a working supply of cleaning items.
- d. Peg Board: The use of peg board is not approved.

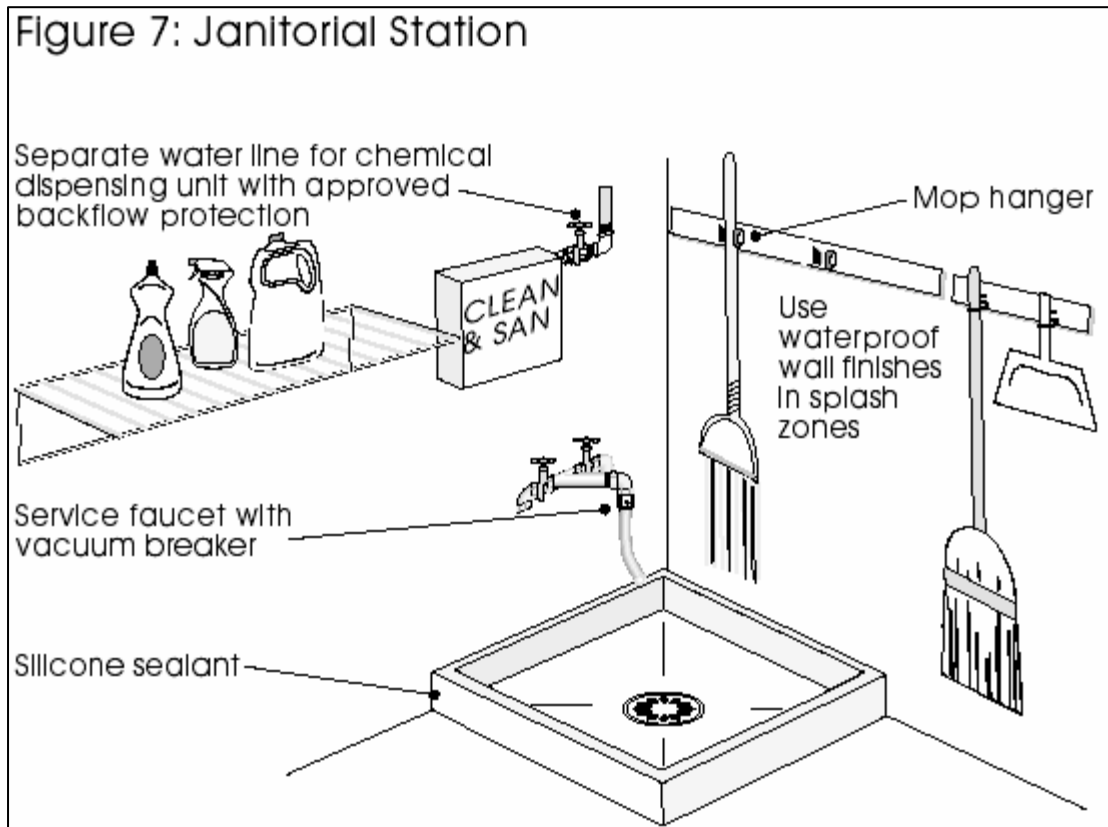

6. Firewood: If firewood is used, designate an area for firewood separate from food service and storage areas. Provide special measures to ensure insect and rodent control.

C. Shelving

Tip: Consider the installation of high-density storage shelving to maximize your available floor space.

- 1. General: Kitchen shelving must meet NSF standards. Shelves shall be constructed of metal or material which has been finished so as to have smooth, easily cleanable, non-absorbent surfaces. Shelves subject to heat or moisture must be of rust-resistant metal. Shelving not approved by NSF may be used in dry storage provided:
 - a. The particular area used is a separate room isolated from other food service operations.

- b. Stored items do not consist of open foods.
 - c. Final approval is reserved for on-site inspection by the Environmental Health Unit.
2. Refrigerators and Freezers: All shelving must meet NSF standards. In addition, shelving installed in refrigerators must be made of rust-resistant metal or other impervious material. The minimum height of a bottom shelf above the floor of a walk-in refrigerator or freezer is 6 inches.

Tip: Consider using heavy-duty dunnage racks for storing case products, heavy containers and bulk products.

V. Employee Areas, Restrooms and Hand Washing Sinks

A. Employee Area

1. Personal Belongings: Specify a coat rack, coat hooks or other suitable facilities for employees to store their clothing and other personal belongings. Consider installing lockers in a designated area.
2. Dressing Rooms: If employees change clothes on-site, provide a dressing room where they may change and store their personal, non-work garments. This cannot be in areas used for storing, preparing or serving food, or for washing or storing utensils.
3. Break Area: Designate a separate break room or area away from food preparation and utensil washing areas if employees are not allowed to eat in the dining room.

B. Restrooms

1. Number: Provide at least the minimum number of toilet facilities for employees required by the local Building Department.
2. Location: Restrooms must be conveniently placed and accessible to employees.
3. Access: Public access to restrooms through food preparation or utensil washing areas is prohibited.
4. Fly Control: Provide completely enclosed toilet rooms with tight-fitting, self-closing doors.
5. Toilets and Urinals: Equip flush tanks with anti-siphon ballcocks. Equip urinals with vacuum breakers on flush valves.
6. Ventilation: Mechanically vent restrooms to the outside of the building.
7. Dispensers: Each hand washing sink must have a supply of dispensed, hand cleansing soap. Also specify dispensed, disposable paper towels. Dispensers must be conveniently located near each hand washing sink. Hand washing sinks for public use may have hot air hand drying devices. If employees share restrooms, it is necessary to provide dispensed, disposable paper towels. Restrooms specifically for employees are to be provided with dispensed disposable paper towels only.

8. Water Supply: Provide each hand washing sink with hot and cold water by means of a mixing valve or combination faucet. Any self-closing, slow-closing, or metering faucet used must provide a flow of water for a minimum of 15 seconds without the need to reactivate the faucet.
9. Refuse Containers: Provide refuse containers for the disposal of paper towels. The recommended placement of refuse containers is near the door so that the door can be opened with a paper towel covered hand to prevent the re-contamination of cleansed hands, and then the paper towel can be discarded in the trash.
10. Sanitary Containers: Provide covered sanitary containers for the disposal of feminine hygiene products.
11. Diaper Changing: Provide diaper changing stations accessible to both male and female patrons, along with covered waste containers. We recommend the containers have tight-fitting lids.

C. Hand Washing Sinks

1. Location: Provide a sufficient number of hand washing sinks. Handwashing sinks must be within the line of sight of each work station, within the same room, and no farther than 20 feet, to allow convenient use in food preparation and utensil washing areas.
2. Bar Areas: A hand washing sink is required within the bar.
3. Water Supply: Provide each hand washing sink with hot and cold water by means of mixing valve or combination faucet.
4. Faucets: Hand washing sink faucets must be equipped with wrist blade type handles, self-closing faucets (i.e. motion detecting faucets), or metered faucets. All motion detecting faucets must be hard-wired, not battery operated.
5. Dispensers: Provide a supply of dispensed, hand cleansing soap and a supply of dispensed, disposable paper towels at each kitchen and bar hand washing sink. A waste receptacle should be near the sink. The use of common towels is not allowed. Hand drying devices using air are not allowed in food preparation and utensil washing areas. Hand sanitizers or gloves may be used in addition to conventional hand washing. They should be placed near your hand washing sinks. Refer to Figure 8 on the following page.
6. Mirrors: The installation of mirrors and medicine cabinets is not allowed at hand washing sinks except if eye wash stations are installed.
7. Splash Protection: Splash guards are needed when a hand washing sink is within 18 inches of a food contact surface, food storage shelves, food service areas, vegetable preparation sink or utensil washing sink. The splash guard must be at least 8 inches high and constructed of stainless steel. Securely fasten splash guards to the wall and counter top or sink. Silicone seal the seam created by the splash guard.

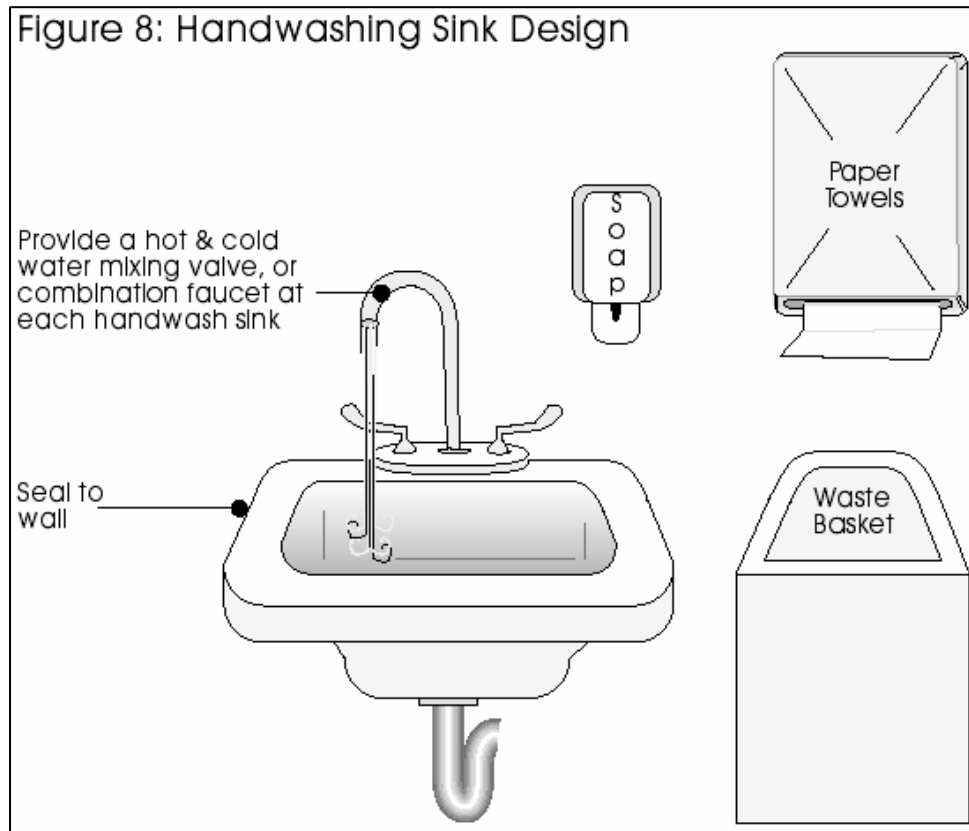

VI. Plumbing

Install and maintain plumbing according to the Illinois State Plumbing Code and all applicable local requirements.

A. Water Supply

Provide an adequate supply of potable water to satisfy the needs of the food service establishment. Water must come from a public water supply or from a Health Department approved private water supply.

B. Sewage Disposal

All water-carried sewage must go to an approved wastewater treatment system. If your facility will be serviced by a private sewage disposal system, contact the Environmental Health Unit for requirements.

C. Grease Interceptors

The local Sanitary District determines the number and size of grease traps, grease interceptors or catch basins required. Contact information for the sanitary districts can be found on page 3 of the Food Service Establishment Plan Review Application.

1. Install an outside grease catch basin with access for maintenance purposes.

2. If an outside grease catch basin is not feasible, install a recessed grease trap in the following manner:
 - a. The lid must be flush with the floor.
 - b. Inlets and outlets must be a minimum of 3 inches in diameter.
 - c. The interceptor must be durable, corrosion-resistant and have a watertight lid securely fastened in place.
 - d. The lid and baffles must be easily accessible for maintenance.

D. Janitorial Sinks

1. Design: Provide janitorial stations for general clean up activities in all food handling facilities. Include either a floor basin sink or a janitorial sink. Installation of a tiled curb area will not be accepted. Connect the basin or sink with a drain to the sanitary sewer. Provide hot and cold water, under pressure, with a mixing faucet and approved backflow protection. Refer to Figure 7 on page 14.
2. Location: Janitorial stations should be conveniently placed for maintaining food service areas. They should be separate from the food preparation and food storage areas. The janitorial basin or sink must be accessible for use during food service operations. More than one janitorial station may be necessary, depending on the size of the operation.
3. Additional Equipment: Other stationary equipment, such as water softeners or water filter systems may not obstruct the mop basin or sink. Allow for space adjacent to the mop sink/janitorial sink for storage of mop buckets. Place chemical dispensing systems so they do not interfere with maintenance equipment storage or use. Install a separate water line for chemical cleaning systems and include appropriate backflow protection. If you suspend a hot water heater over the mop basin, maintain a minimum clearance of 80 inches to provide adequate space for the storage of wet mops.

E. Overhead Sewer Lines

Location: Waste lines and roof drains shall not be directly above food preparation, food display, food storage and utensil washing areas.

F. Potable Water Backflow Protection

1. Inlets: All water inlets (faucets, etc.) must have an air gap between the water inlet and the fixture it is serving. The air gap must be twice the diameter of the water inlet or faucet. Any water inlet, faucet, etc., that does not meet this requirement is a submerged inlet. A water faucet that can have a hose attached to it is a submerged inlet.
2. Vacuum Breakers: Provide vacuum breakers on submerged inlets such as toilets, urinals, dish washing machine, garbage grinders and any threaded water outlets.
3. Special Conditions: Provide double check valves with atmospheric vents or reduced pressure zone backflow preventers capable of being submerged on water inlets where you cannot install a vacuum breaker after the last shut-off valve or solenoid switch (i.e., pressure spray hoses).

4. Carbonators: Carbonators must have double check valves plus equipment to meet any other specific Illinois State Plumbing Code requirements. Refer to Figure 9 below.

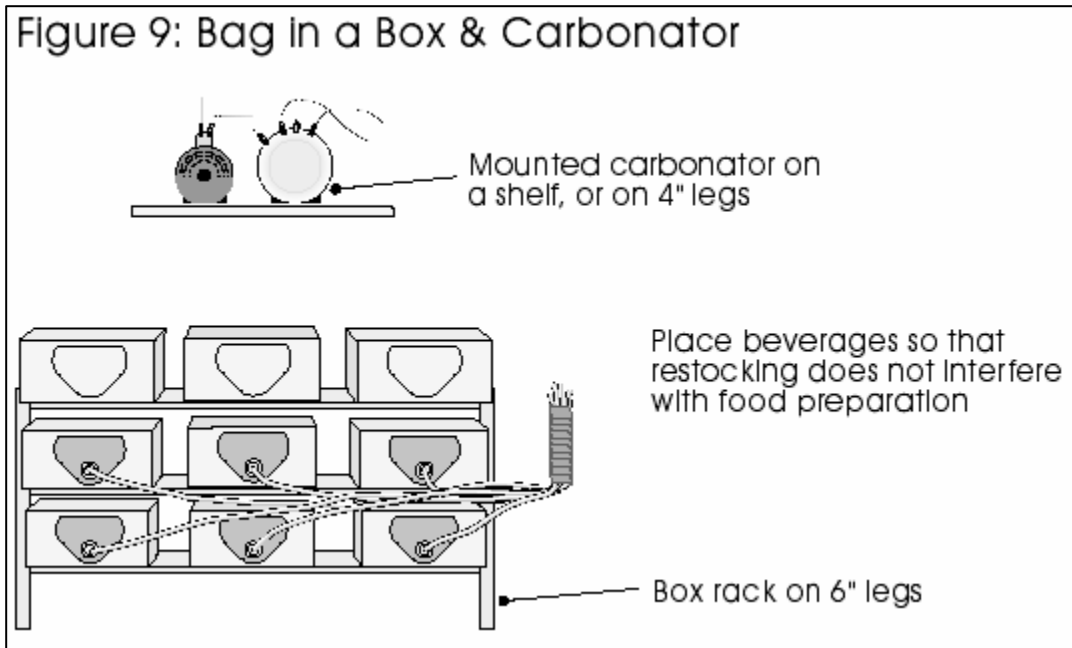

G. Indirect Waste Connections

1. Equipment Drains: Provide indirect wastes for dish washing machines, dish washing sinks, pot washing sinks, pre-rinse sinks, silverware sinks, bar sinks, soda fountain sinks, potato peelers, ice machines, steam tables, steam cookers, ice bins, salad bars, dipper wells, walk-in refrigerator or freezer condensate and other similar fixtures. Refer to Figure 10 on the following page.
 - a. An indirect connection discharges waste through an air gap into the drainage system. Do not connect it directly with the drainage system.
 - b. The indirect piping from the fixture to the air gap must not exceed 5 feet.
 - c. Indirectly connected fixtures must discharge to a vented trap placed as close as possible to the fixture and in the same room. To avoid cross connections, each fixture will require a separate line.
 - d. Install receptors (floor sinks, etc.) receiving indirect wastes in accessible and ventilated areas. Design and size receptors to prevent overflows and splashing. If installed inside cabinets, the cabinetry shall have no base or base shelf and an open to the floor design. It is highly recommended that floor sinks be provided in this type of installation.
 - e. Food service equipment, sinks or buckets cannot receive the discharge of an indirect waste pipe.

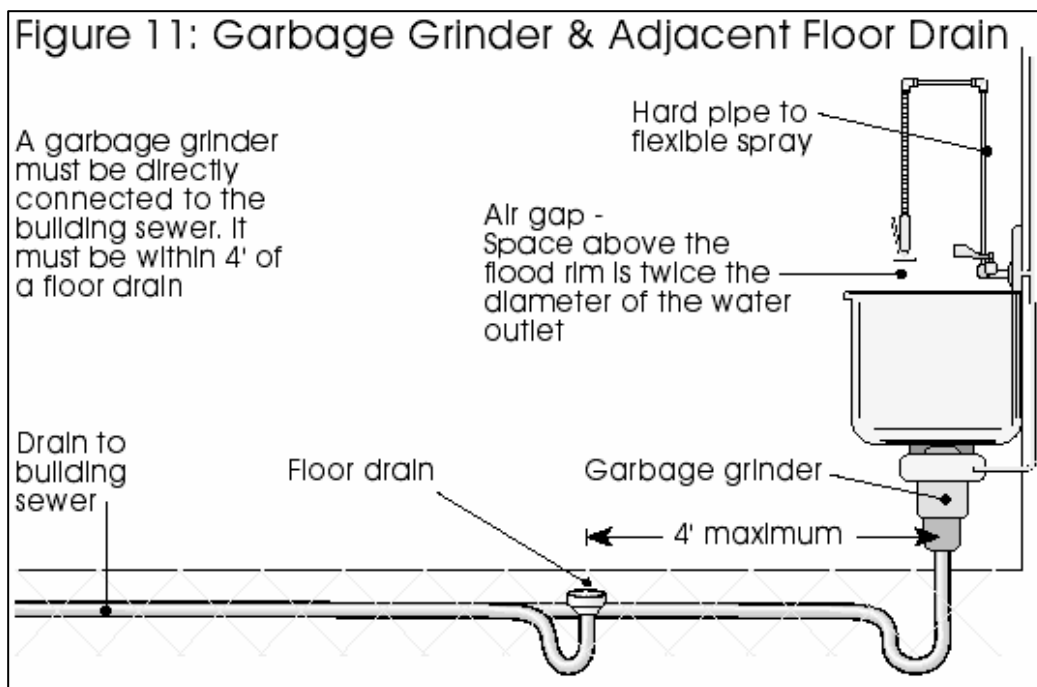

VII. Sanitizing Equipment

A. Hot Water System

1. Minimum Size: A 40-gallon minimum capacity water heater is required for a facility with a three-compartment sink, hand wash sink and utility sink. For limited facilities with less need for hot water, we can evaluate the capacity according to the type of fixtures provided.
2. Dish Washing Machine Demand: Facilities using a commercial dish washing machine must provide hot water (temperature and volume) to meet the maximum demand for the make and model of machine to be installed.
3. Heat-On-Demand Units: A hot water system that does not provide any storage capacity may be approved for use in a food service facility if properly sized. All specifications must be provided to this department for approval.

B. Manual Utensil Washing

1. Design: Provide a three-compartment, stainless steel sink with two integral drain boards where pots, pans or multiuse eating and drinking utensils are washed by hand. Install this sink to minimize cross-contamination to, or from, your janitorial station or food processing tables.
2. Size: Each compartment must be large enough to submerge the largest item to be washed. Each drainboard must equal the area of the largest compartment.

C. Mechanical Utensil Washing

1. General Requirements

- a. All spray-type dish washing machines must comply with the current edition of NSF *Standard #3*.
- b. A soiled dish table of adequate size is needed to handle soiled utensils before washing. The soiled dish table must not drain into the washing compartment of the dish washing machine. Install a table scupper across the entire flat section of the table to prevent soiled water and debris from draining into the wash tank. Install a pre-rinse sink as needed so that larger food particles can be rinsed off before entering the dish washing machine.
- c. A clean dish table or drainboard large enough to allow water to evaporate from dishes and utensils is needed. This installation must provide room for the temporary storage of utensils and racks immediately after being removed from dish machines. Slope the clean dish table to drain into the machine. It must be at least the size of the soiled dish table.
- d. Easily readable, numerically scaled indicating thermometers are needed. They must be accurate to $\pm 3^{\circ}\text{F}$ and show the temperature of the water in each tank of the machine, including the temperature of the final rinse water as it enters the manifold.
- e. Mechanical exhaust ventilation is required over the dish washing machine to remove steam and vapors effectively.
- f. The installation of integral manual and mechanical dish washing drain boards will not be accepted due to cross-contamination concerns.

2. Chemical Sanitizing Machines

- a. A sanitizer alert system which includes a visual and audible alarm, designed and approved for the specific machine installed, is needed to warn the user automatically when the sanitizer supply has depleted.
- b. Additional drain boards or dish tables for air drying utensils after being washed in a low-temperature machine will be needed.

3. Hot Water Sanitizing Machines

- a. A booster heater is needed to heat 140°F water to at least 180°F for the final rinse of the dish washing machine. The temperature rise demand of the dish washing machine will determine the heater size.
- b. A temperature gauge on the service line just before the booster heater is required.
- c. Installation of the hot water heater and the booster heater should be as close as possible to the dish washing machine to avoid heat loss in the lines.
- d. The water system should deliver hot water to the final rinse when the rinse valve opens. Machines designed for intermittent operation will require special equipment. When the length of the line from the booster to this type of machine exceeds 50 feet, the system should be re-circulating.

- e. A pressure regulator is needed on the final rinse line. The flow pressure needs to be 15 to 25 pounds per square inch.
- f. A thermometer and pressure gauge on the final rinse line is needed. You must install the pressure gauge after the pressure regulator as close to the manifold as possible. Install a valve with standard threads upon which you may attach a pressure gauge to check flow pressure. Refer to Figure 12 below.

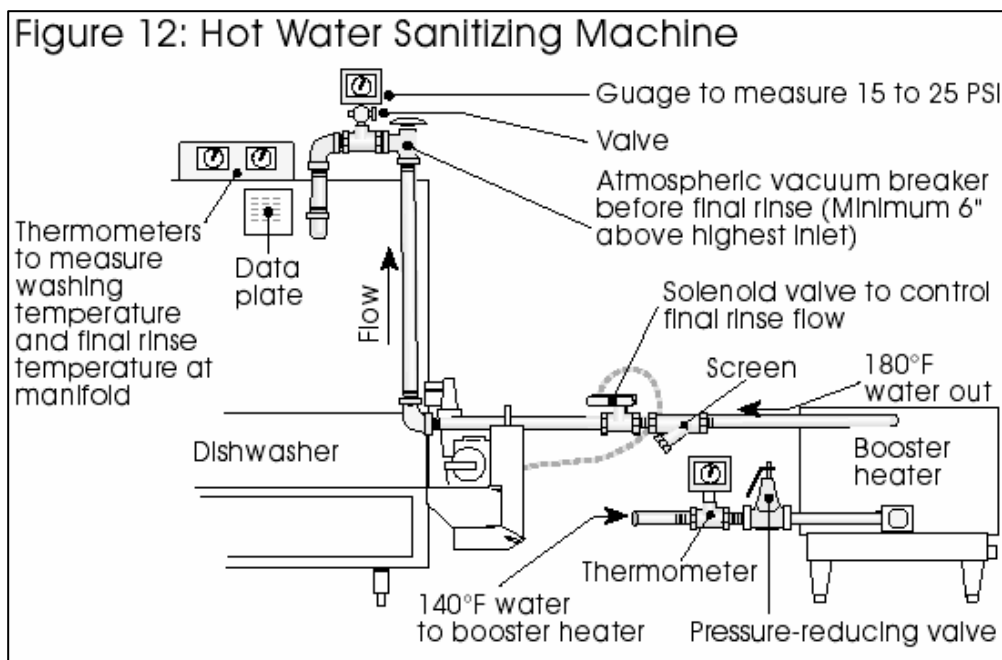

VIII. Lighting

A. Food Service Areas

Food preparation and utensil washing areas must be well lit. A light intensity of 50 foot-candles measured 30 inches above the floor is necessary.

B. Walk-In Refrigeration and Freezers

Walk-in units must be well lit to provide at least 30 foot-candles of light throughout. Install fluorescent lights with cold-tolerant ballasts and vapor-proof fixtures. Install lights so that lighting will not be obstructed by food stored on shelves.

C. Storage and Restrooms

Provide at least 30 foot-candles of light, measured 30 inches above the floor, in storage rooms and restrooms.

D. Bars

Dimmer switches may be a suitable alternative for use in bar areas. Provide additional lighting for clean-up purposes.

E. Protection Against Breakage

Protective shielding for light fixtures is needed over all food preparation, display, service, storage and utensil washing areas. Explosion tubes with end caps or shatterproof fixture lenses may be used. Protect heat lamps against breakage with a shield surrounding and extending beyond the bulb, leaving only the face of the bulb exposed. You may use coated, shatterproof bulbs instead of shielding.

IX. Laundry

A. Location

Install laundry in a separate room with a door to separate food service operations from any laundry area. We recommend that you provide a vented door grill to exhaust heat from the room.

B. Clothes Dryer

If you provide a clothes washing machine, you must also provide a dryer. Dryers must be vented to the outside.

C. Linens

For clean and soiled linen storage, see Section IV. B, *Storage Locations*.

X. Room and Area Finishes

A. Food Preparation and Food Storage Areas

1. Floors: Floor finishes must be of durable, light-colored, waterproof, grease-resistant and easily cleanable material.
 - a. Commercial grade vinyl composition tile flooring is the minimum grade material acceptable.
 - b. The use of poured monolithic floors requires specific approval for kitchen applications. Manufacturer's specification sheets must be provided. This type of application must be seamless and **FDA approved** for use in a food facility.
2. Coving: A 3/8 inch base coving must be provided at the juncture of the floor and wall.
3. Walls: Construct walls with a smooth and easily cleanable material that has a light-colored finish.

- 4. Ceilings: Install smooth, non-absorbent and light-colored ceilings that can withstand frequent cleaning. Exposed joists, studs or other support structures will not be accepted.

B. Cookline

Wall finishes behind the cookline must be of stainless steel or its equivalent.

Note: Permanent outdoor cooking (i.e., grilling) is not permitted by the State of Illinois or the KCHD rules and regulations. A Temporary Food Permit for defined special events may be obtained by contacting KCHD.

C. Utensil Washing and Janitorial Station Areas

- 1. Finishes must meet the same requirements as Section X. A, *Food Preparation and Food Storage Areas*.
- 2. In addition, the splash zone must be finished with a durable and waterproof material such as fiberglass reinforced panels (FRP) or stainless steel.
 - a. The splash zone for utensil washing areas is considered to be floor to 18 above the top edge of the equipment backsplash.
 - b. The splash zone for a mop sink is considered to be floor to 36 inches above the top edge of the equipment.
- 3. Painted drywall is not acceptable.

D. Walk-In Refrigerator or Freezer Units

Note: Galvanized metal will rust when used as a finish in a walk-in cooler. It is not accepted.

- 1. Floors, Walls and Ceiling: Fabricate and install finishes that are NSF approved, waterproof, corrosion resistant, free of difficult-to-clean internal corners and crevices, and durable under conditions of normal use.
- 2. Coving: We recommend the installation of screeds so that you have an effective 3/8 inch radius cove on both the interior and exterior of the unit. Other approved methods include a grout radius as an integral part of the flooring material or corrosion-resistant metals. Because of breakage and separation problems, you should avoid using tile or vinyl base as coving. Refer to Figure 13 below.

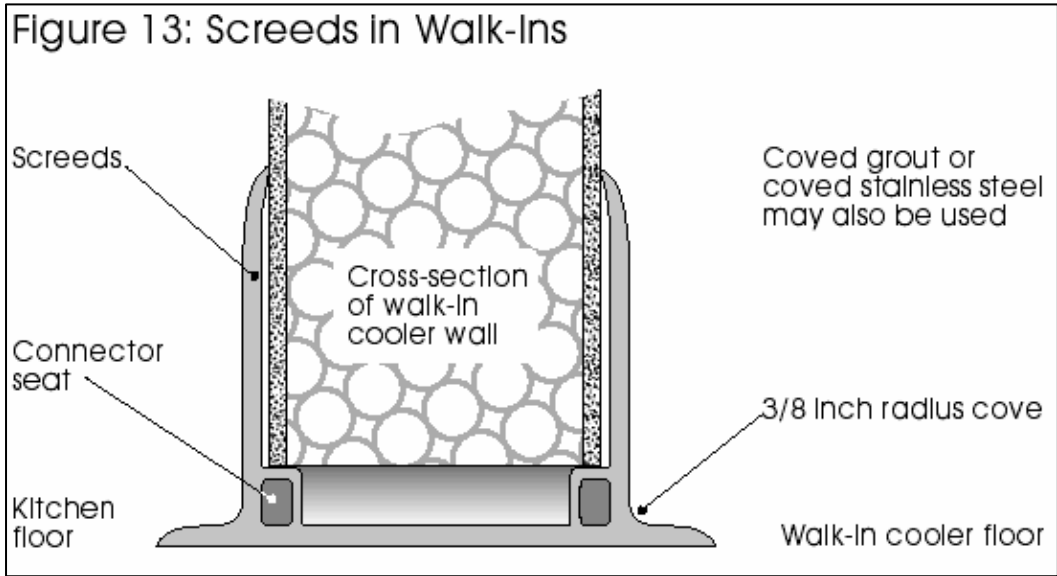

E. Server, Pick-Up or Wait Stations

Server stations without plumbing connections, located within a dining room, may use the same wall and ceiling finishes as the dining room. Server stations with plumbing connections or those extending from the kitchen must utilize the same room and area finishes as stated in Section X. A, *Food Preparation and Storage Areas*, with the following modifications:

1. Floors: In food pick-up stations or wait stations with plumbing, specify floors of durable, waterproof and easily cleanable material extending a minimum of 3 feet from the counter in all directions.
2. Coving: A 3/8 inch base coving must be provided at the juncture of the floor and wall. Kick plates are not to be used because they do not adequately seal the area from the entrance of debris.
3. Walls: Walls must be easily cleanable.
4. Ceilings: Smooth, non-absorbent and light-colored ceilings that can withstand frequent cleaning must be installed at any station where food is picked up.
5. Floor cabinetry must be installed on legs (a minimum of 6 inches in height), or have an open-to-the floor design, with no base shelf in order to prevent potential pest harborage areas and to provide easy access to the floor for cleaning. All cabinetry finishes must be smooth, non-absorbent and easily cleanable (i.e., plastic laminate). Exposed wood trim is not permitted in food areas.

F. Bar

1. Floors: Floor finishes must be of durable, light-colored, waterproof, grease-resistant and easily cleanable material.
2. Coving: A 3/8 inch base coving must be provided at the juncture of the floor and wall.
3. Walls: Walls may have the same finish as the rest of the room except that the interior bar wall surfaces and undersides of the bar counter tops must have smooth, nonabsorbent and light-colored finishes that can withstand frequent cleaning. Exposed joints or other support structures will not be accepted. In addition, the splash areas must be finished with a durable and waterproof material such as ceramic tile, FRP or stainless steel. Refer to Figure 14 on the following page.
4. Ceilings: Ceilings may be of the same finish as the dining room.

G. Restrooms, Dressing and Locker Rooms

1. Floors: Floor finishes must be of durable, light-colored, waterproof, grease-resistant & easily cleanable material.
2. Coving: A 3/8 inch base coving must be provided at the juncture of the floor and wall or cabinet.
3. Walls: Construct walls with a smooth and easily cleanable material that has a light-colored finish. In addition, it is recommended that partitions and wall finishes behind fixtures subject to splash such as toilets and urinals be upgraded with waterproof materials such as stainless steel, FRP or ceramic tile.

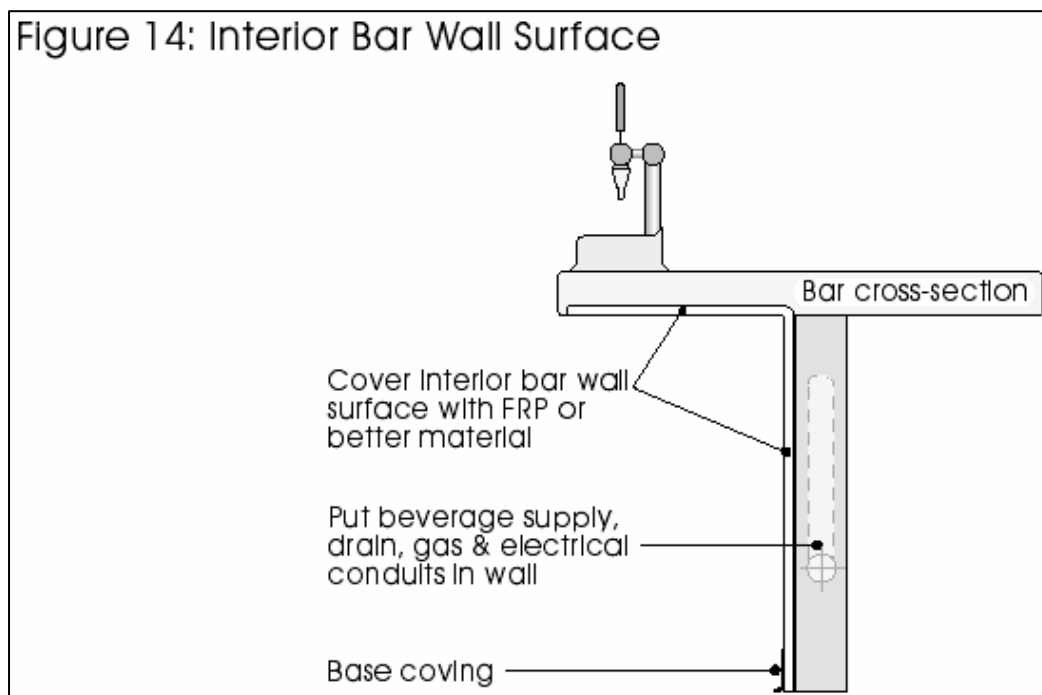

H. Dining Rooms

Carpeting, if used as a floor covering, must be of closely woven construction, properly installed, easily cleanable and maintained in good repair.

I. Buffets, Salad Bars and Beverage Stations

1. Floors in Dining Areas: Floor finishes must be of durable, light-colored, waterproof, grease-resistant and cleanable materials extending at least 3 feet from all sides of buffets, salad bars and beverage stations.
2. Coving: A 3/8 inch base coving must be provided at the juncture of the floor and wall.
3. Walls: When the buffet is placed against a wall, the wall must be smooth and non-absorbent.
4. Ceilings: You may use the same finish as the dining room.
5. Floor cabinetry must be installed on legs (a minimum of 6 inches in height), or have an open-to-the floor design, with no base shelf in order to prevent potential pest harborage areas and to provide easy access to the floor for cleaning. All cabinetry finishes must be smooth, non-absorbent and easily cleanable (i.e., plastic laminate). Exposed wood trim is not permitted in food areas.

J. Areas with Multiple Uses

Any area used for a combination of previously defined activities must meet the more stringent requirements imposed on that area or activity.

K. Summary of Room and Area Finishes (Refer to Table 1 on the following page)

1. Floors: Quarry tile is a preferred flooring because of its durability. The use of diamond-plate steel or corrosion-resistant aluminum as flooring under beer kegs, or where durability is essential, should be considered.
2. Walls: Stainless steel, fiberglass reinforced panel (FRP), and ceramic tile meet the standard for durability and being waterproof in splash zones. Oil-based epoxy paints are appropriate in food storage areas. High-gloss enamel paints work well in most other areas. We recommend stainless steel corner guards in high-traffic areas.
3. Ceiling: Lay-in smooth, non-fissured, vinyl-clad gypsum board for dropped ceilings. Drywall painted with a washable finish may also be used.
4. Floor cabinetry must be installed on legs (a minimum of 6 inches in height), or have an open-to-the floor design, with no base shelf in order to prevent potential pest harborage areas and to provide easy access to the floor for cleaning. All cabinetry finishes must be smooth, non-absorbent and easily cleanable (i.e., plastic laminate). Exposed wood trim is not permitted in food areas.

Table 1: Summary of Room and Area Finishes				
Room or Area Examples	Floors	Coving	Walls	Ceilings
Food Preparation Food Storage Cookline	<ul style="list-style-type: none"> • Light colored • Waterproof • Grease resistant • Easily cleanable • Durable 	<ul style="list-style-type: none"> • 3/8" radius cove • Sealed 	<ul style="list-style-type: none"> • Light colored • Easily cleanable • Stainless steel behind cookline 	<ul style="list-style-type: none"> • Light colored • Non-absorbent • Smooth • Durable
Utensil Washing Janitorial Stations	<ul style="list-style-type: none"> • Light colored • Waterproof • Grease resistant • Easily cleanable • Durable 	<ul style="list-style-type: none"> • 3/8" radius cove • Sealed 	<ul style="list-style-type: none"> • Light colored • Easily cleanable • Durable • Waterproof in splash zones 	<ul style="list-style-type: none"> • Light colored • Non-absorbent • Smooth • Durable in splash areas
Walk-In Coolers Refrigerators & Freezers	<ul style="list-style-type: none"> • Corrosion resistant • Waterproof • Easily cleanable 	<ul style="list-style-type: none"> • 3/8" radius cove • Sealed • Inside & outside unit 	<ul style="list-style-type: none"> • Corrosion resistant • Easily cleanable 	<ul style="list-style-type: none"> • Corrosion resistant • Waterproof • Easily cleanable
Server Areas	Within 3 ft of counter: <ul style="list-style-type: none"> • Waterproof • Easily cleanable 	<ul style="list-style-type: none"> • 3/8" radius cove • Sealed • Include cabinets 	<ul style="list-style-type: none"> • Easily cleanable 	<ul style="list-style-type: none"> • Light colored • Smooth • Durable
Bar	<ul style="list-style-type: none"> • Light colored • Grease resistant • Easily cleanable • Durable 	<ul style="list-style-type: none"> • 3/8" radius cove • Sealed 	Back of the bar & under bar top: <ul style="list-style-type: none"> • Light colored • Waterproof • Easily cleanable • Durable 	May be the same as the dining room
Restrooms Dressing Areas Locker Rooms	<ul style="list-style-type: none"> • Light colored • Waterproof • Grease resistant • Easily cleanable • Durable 	<ul style="list-style-type: none"> • 3/8" radius cove • Sealed 	<ul style="list-style-type: none"> • Light colored • Waterproof • Easily cleanable • Durable • Water resistant 	
Buffets Salad Bars Beverage Stations	Within 3 ft of counter: <ul style="list-style-type: none"> • Light colored • Waterproof • Grease resistant • Easily cleanable • Durable 	<ul style="list-style-type: none"> • 3/8" radius cove • Sealed 	If placed against a wall: <ul style="list-style-type: none"> • Smooth • Waterproof 	May be the same as the dining room
Combination Areas	Any area used for a combination of activities must meet the more stringent requirements			

XI. Insect and Rodent Control

A. Building

1. All masonry or cement foundations must be rodent proof.
2. Cover all building vents with a minimum of 16 mesh per inch wire screen.
3. Seal openings into the foundation and exterior walls around pipes, wires or conduits.
4. Tightly seal the opening around conduits or pipelines entering a wall, ceiling or floor.

B. Delivery Doors

1. Pest Control: All delivery doors leading to the outside must be self-closing and tight fitting.
2. Garage Doors: Vertically-opening, garage-type delivery doors must be protected against pests. They should have an overhead air curtain with a minimum velocity of 750 feet of air per minute measured 3 feet above the floor. We will consider suitable alternatives for pest control for this type of door.
3. Entrance Doors: Make all outside customer doors self-closing and tight fitting. You may need to adjust the threshold sweep to prevent the entrance of insects and rodents. Automatic sliding customer doors must be provided with an overhead air curtain with a minimum velocity of 750 feet of air per minute, measured 3 feet above the floor.

C. Windows

1. Screen all openable windows, except drive-thru or walk-up windows, with at least 16 mesh to the inch screening.
2. Provide fly protection by one or more of the following methods:
 - a. Self-closing: Equip windows with a self-closure device, such as a spring-loaded bump pad or an electronic opener. Refer to Figure 15 on the following page.
 - b. Air curtain: Install an air curtain so that a layer of fast moving air is produced vertically downward. The air flow runs parallel with the window and within 1 inch (inside or outside) of the window opening. The air curtain must protect the entire width of the window opening. Minimum air velocity is 750 feet per minute, measured at the furthest point in the window opening from the air curtain. Use a solenoid switch to activate the unit. Manual switches will not be accepted.
 - c. Fly fans: Mount one fan, within 12 inches of the wall, over each window. Each fan must produce a minimum downward air velocity of 750 feet per minute along the entire horizontal width of the window opening.

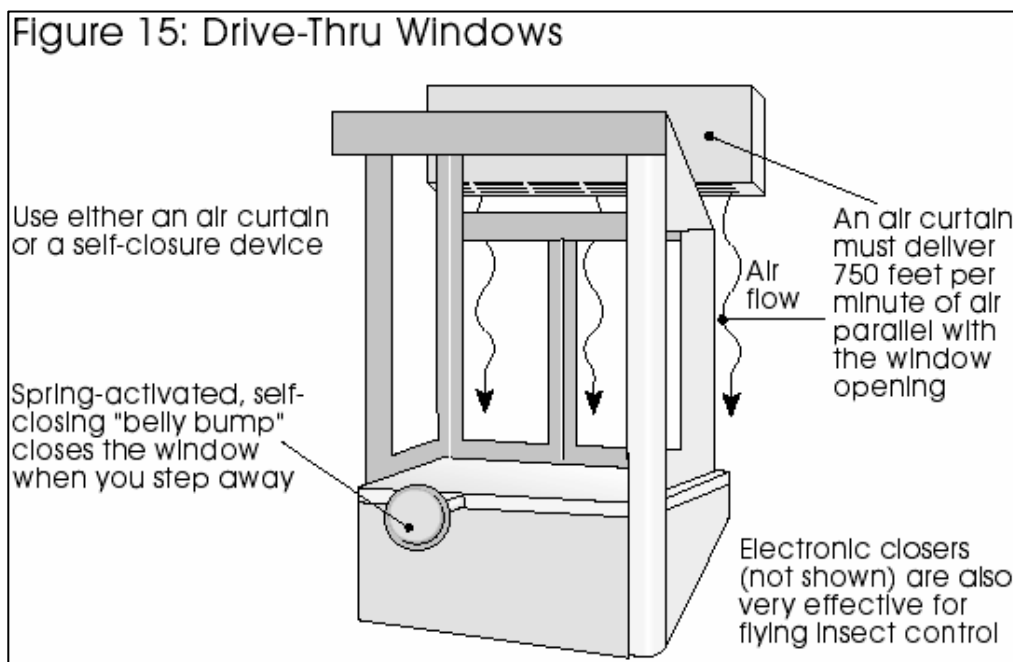

XII. Garbage and Refuse

A. Garbage Containers

1. Number: Each food facility is to secure their own garbage service. Remember to provide sufficient garbage containers, sized to hold any garbage or refuse in a nuisance-free manner, until it can be picked up by a disposal company.
2. Trash Compactors: The cleaning and proper disposal of the liquid waste requirements may vary from municipality to municipality.
3. Incinerators: Incinerators must have EPA approval and comply with all state and local regulations, if operated.

B. Garbage Area

1. Outside Storage: Place outside refuse containers and compactor systems on smooth surfaces of non-absorbent material such as concrete or machine-laid asphalt. Use a concrete pad for storing grease containers. These areas should be as far as possible from the building's doors and windows.
2. Pest Control: When outside refuse containers are within 20 feet of the food facility's door or window, install an air curtain, in addition to a self-closure device on doors. Air curtains must maintain a minimum velocity of 750 feet of air per minute measured 3 feet above the floor.
3. Enclosures: If you propose a garbage enclosure, construct it of durable, non-absorbent materials and a washable interior finish able to withstand frequent cleaning.

4. Recycling: If you plan to recycle, check with your local municipality or waste management company for additional rules, guidelines or details. You should plan for possible mandatory recycling and make arrangements for future outside storage of the recycled materials.
5. Inside Storage, Interior Garbage Storage, Refuse Rooms, Grease Storage:
 - a. If used, garbage room and area finishes must meet the same requirements as the food preparation area. See Section X. A, *Food Preparation and Food Storage Areas*.
 - b. Indoor garbage room temperatures of 50°F or less should be maintained to eliminate fly breeding.

XIII. Exhaust Hood Ventilation for Cook Line Equipment

A. Exhaust Plans Submittal

1. Specifications: Submit exhaust plans along with manufacturer's specifications indicating the type of equipment being proposed for installation under the cook line exhaust hood.
2. All installations must be in complete accordance with all municipal, county, state, fire and building department requirements and recommendations.
3. The local building department shall have final approval for all exhaust systems.

B. When Exhaust Hoods Are Required

1. Type I hoods are required for food service equipment that produce smoke, grease laden vapors, particulate matter, and odors. A type I hood is defined as a stainless steel hood certified by UL, NFPA, or NSF with a fire suppression system. Type I hoods must also meet factory engineered performance standards. Examples of equipment requiring this type of hood system include but not limited to: stoves, ranges, fryers, ovens, broilers, hot plates (except induction cookers), and salamanders.
2. Type II hoods are required for all food service equipment that produces steam, mist, heat and vapors. A type II hood is defined as a stainless steel hood certified by UL, NFPA, NSF and usually do not require a fire suppression system. Type II hoods must meet minimum performance standards. Examples of equipment requiring this type of hood system include but are not limited to pizza ovens, gas convection ovens, pasta cookers, conveyor ovens, bain maries, kettles and dishwashers.
3. Exceptions: A commercial exhaust hood is required for each cooking appliance, with the following exceptions:
 - a. Completely enclosed ovens
 - b. Steam tables
 - c. Auxiliary cooking equipment that does not create a sanitation or indoor air quality problem, for example: toasters, coffee makers, sandwich makers, electric rice cookers, electric cheese melters and soup wells.

- d. Table-side cooking
- e. Special temporary event set-ups (less than 14 days)

C. Size of the Exhaust Hood

The size of the exhaust hood is determined by the overall length of the equipment to be located under the hood. The hood system must capture all air rising off of the equipment at maximum input.

D. Exhaust Ducts

1. Construction: All ducts should be constructed with a minimum of bends. Ducts are to be smooth, easily cleanable and made of a corrosion-resistant metal.
2. Number: Multiple takeoff ducts are required for all hoods 12 feet or more in length. When required, multiple ducts must be equally spaced. Consult the local building authority for calculations.
3. Velocity: Duct air velocity must be a minimum of 1,500 feet per minute, with a maximum of 1,800 feet per minute.
4. Outside Exhaust: Kitchen exhaust systems must be designed and constructed to exhaust the air through duct(s) directly to the outside atmosphere in a safe and nuisance-free manner.
5. Interference With Other Fuel-Burning Equipment: Kitchen hoods and ducts must be designed so they will not interfere with normal combustion processes or combustion exhausts from commercial cooking or heating equipment. Locating a water heater or a furnace near the kitchen exhaust system is not recommended.

E. Exhaust Filters/baffles

1. Size: All exhausted air, before entering the duct work, must pass through approved, removable baffle filters or grease extractors. Calculate the appropriate number of baffles/extractors needed, based on the length of the filter bank and the size of the baffles/extractors.
2. Design: Baffles or extractors must be installed at a 45 degree angle and shall be sized appropriately to fit the hood. Spacers may be needed to eliminate any gaps between baffles. Installation of spacers over grease-producing equipment is not approved.
3. Type: Baffles or extractors specified must be of the same type so they will not adversely affect the static pressure of the total system. Mesh filters are not approved for Type I hoods.
4. Installation: Baffles or extractors must be installed vertically to channel grease accumulation to the collection container.

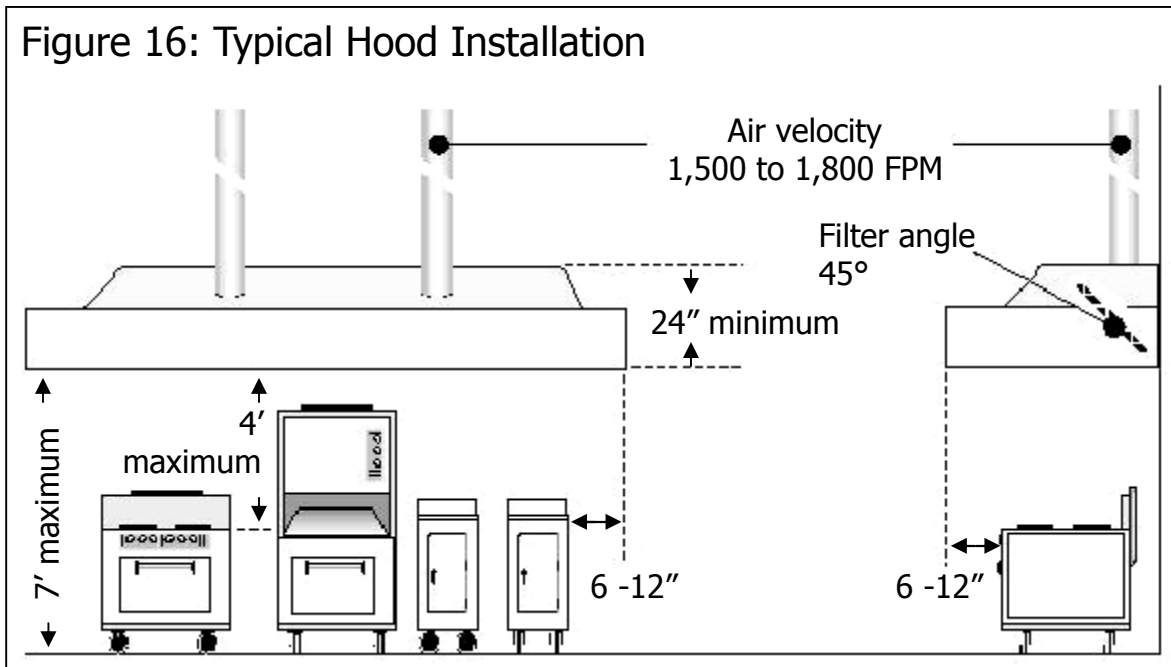

F. Exhaust Fan

1. Specifications: All fan specifications (make and model) must be compatible with the proposed exhaust system.
2. Location: All fans must be located to direct exhaust away from the building in a safe and nuisance free manner.

G. Make-Up Air

1. Balanced Air Flow: Exhaust systems with air removal of over 1,500 CFM must be provided with sufficient make-up air equal to or slightly less than the total CFM to be exhausted.
2. Tempering: The make-up air is to be introduced in a manner which will not interfere with the capture characteristics of the exhaust system nor create discomfort to the employees.
3. Quality: The air supplied to the kitchen and food preparation areas must be free from contamination by dust, vapors or gases. Screening must be provided to prevent ingress of foreign matter.

H. Construction and Criteria Checklist: Please check all requirements that are met:

- The hood is constructed of stainless steel.
- The maximum distance between the bottom edge of the hood and the floor is seven (7) feet.
- The maximum height of the bottom edge of the hood above the cooking surface is four (4) feet.
- The minimum height of the hood itself is twenty-four (24) inches.
- The minimum static pressure is one-half (1/2) inch.
- Hoods located less than eighteen (18) inches from the ceiling or wall must be closed with approved material to the ceiling and wall.
- The minimum distances between the lowest edge of a baffle or extractor and the cooking or heating surface are three (3) feet for exposed or unexposed flame units and four (4) feet for charcoal.
- A minimum of fifty (50) foot candles of light is provided in the hood, measured six (6) inches above the cooking surface. Protective light globes are provided on lighting.
- Fire suppression tanks are not located over sinks or food preparation equipment.
- Horizontal runs of exposed piping or fusible links of the fire protection system below the filter bank in the hood or the make-up air plenum are not present. Exposed piping/conduit on the exterior of the exhaust hood is spaced one-half (1/2) inch to one (1) inch away from all surfaces.
- Fire suppression piping is of easily cleanable material such as stainless steel or chrome.
- Plumbing and electrical conduit is concealed behind the wall.
- Exposed gas lines are elevated to at least six (6) inches above the finished floor and spaced one-half (1/2) inch to one (1) inch away from all surfaces.
- Obstructions such as shelving or pot racks are not installed between the cooking equipment and the ventilation filter bank.
- Air intakes are located at least ten (10) feet away from any exhaust outlet or vent.
- Insulation is not applied on the interior of the ductwork.
- All gas lines are vinyl coated quick disconnect lines, and elbow at the wall.

Index

A

- Air curtain 30
- Air gap 18, 19, 20
- Air velocity, insect control 30
- Alarm, chemical sanitizer 22
- Anti-siphon ballcocks on toilets 15
- Application, plan review 5
- Area finishes 24, 25, 26, 27, 28, 29
- Atmospheric vents for submerged inlets 18

B

- Backflow protection
 - chemical dispensers 18
 - janitorial sinks 18
 - submerged inlets 18
 - toilets, urinals 18
- Backwater valves 20
- Bar
 - handwashing sink 16
 - indirect wastes 19
 - lighting 24
 - room finishes 26
- Beverage
 - display coolers 12
 - station area finishes 27
 - storage calculation 13
- Blast chillers 12
- Booster heater, hot water sanitizing 22
- Break area 15
- Broom racks 14
- Buckets as drains 19
- Buffets
 - area finishes 27
 - cold display 13
 - open food display 7
- Building Department
 - exhaust system requirements 32
 - grease interceptors 17
 - requirements 2
 - restrooms 15
 - trash compactors 31

C

- Cabinetry 26, 27, 28
- Calculating
 - dry storage 13
 - hot water capacity 21

- refrigeration space 11
 - ventilation system 33
- Carbonators, backflow protection 19
- Carpeting, dining rooms 27
- Casters 9
- Catch basins 17, 18
- Ceilings
 - area finishes 25, 26, 27, 28, 29
 - spacing from equipment 9, 11, 13, 35
 - spacing from utility lines 11, 30
- Check valves
 - on carbonators 19
 - on water inlets 18
- Cheese melters 8, 32
- Chemical
 - dispensing equipment 18
 - backflow protection 18
 - location 18
 - sanitizing machines 22
 - storage 13
- Chest freezers, domestic 11
- Chrome
 - fire suppression piping 35
 - shelving in refrigerators 14
- Clean dish table 22
- Clothes dryer 24
- Cloth storage (see linens) 13
- Clothing storage, employee 15
- Cold plates 7
- Combination faucet 16
- Compactors 31
- Conduits 11, 30
- Construction inspections 5
- Containers
 - garbage storage 31
 - grease 31
 - linens, uniforms 13
 - restroom refuse 16
- Cooking outdoors 25
- Cookline ventilation 5, 8, 32
- Coolers
 - produce floor drains 20
 - refrigerators and freezers 11, 12
- Curbed drains 18
- Customer service refrigerators 11, 12

D

- Deflector, heat, vapor 8
- Delivery
 - area 12, 13
 - doors, pest control 30
- Diaper changing tables 16
- Dining rooms, carpeting 27

- Dipper wells
 - for food scoops 7
 - indirect waste 19
- Dish washing machine
 - adjacent floor drain 20
 - backflow protection 18
 - hot water demand 21
 - indirect waste 19
 - submerged inlet 18
- Dispensers
 - single service utensils 7
 - soap, towel 15, 16
- Display
 - cases, protection 8
 - refrigerators 12
- Domestic refrigerators 11
- Doors
 - customer 30
 - delivery 30
 - distance to garbage area 31
 - garage 30
 - laundry room 24
 - near storage room 13
 - on plans 5
 - produce coolers 20
 - restroom 15
- Double check valves 18
 - on carbonator 19
- Drain boards 21, 22
- Drains
 - curbed 18
 - floor 20
 - indirect wastes 19
 - overhead 18
- Dressing rooms
 - area finishes 27, 29
 - use 15
- Drive-thru windows
 - Construction 9
 - Pest control 30
- Dry Storage 12, 13, 14
- Ducts, ventilation system 33

E

- Employee area 15
- Entrance doors 30
- Equipment
 - backsplash 25
 - chemical dispensing 18, 21
 - drains 19
 - exhaust 32
 - filtration 18
 - floor drain placement 20
 - floor-mounted 9

- food flow 11
- hot water sanitizing 22
- inspections 5
- installation 9, 11, 12, 13
- maintenance 14
- materials and design 7
- needs 5
- plan review 5
- single service dispensing 7
- spacing 9
- table-mounted 9
- Estimating
 - dry storage 13
 - hot water capacity 21
 - refrigeration space 11
 - ventilation system 32
- Exhaust
 - checklist 35
 - equipment 8
 - fan 34
 - filters 33, 34, 35
 - for dish washing machine 22
 - from restrooms 15
 - hoods 32
 - laundry 24
 - make-up air 34
 - plan review 5, 32
- Explosion tubes 24
- Eye wash stations, mirrors 16
- F**
- Fees 5
- Filters 18, 33, 34, 35
- Final inspections 5
- Fire protection requirements 2, 32, 35
- Firewood storage 14
- Floor-mounted equipment 9
- Floors
 - area finishes 24, 25, 26, 27, 28, 29
 - basin sink 18
 - building out pests 30, 31
 - cabinetry 27
 - clearance 13, 14, 15
 - drains 20
 - sinks 19
- Fly control 15
- Food
 - area finishes 24, 25
 - lighting 23, 24
 - flows 2
 - open display 8
 - preparation sink 7, 16
 - splash guard 16
 - work surface 7

- Foundations 30
- Freezers 11, 12, 15, 23
- FRP 25, 26, 28
- G**
- Galvanized shelving in refrigerators 25
- Garage doors 30
- Garbage
 - area 31, 32
 - containers 31
 - grinders, backflow protection 18, 20
 - restroom receptacles 16
- Grease interceptors 17
- Grilling, outdoor 25
- Gutters, sewer lines 18
- H**
- HACCP, planning 2
- Hand washing sink
 - bars 16
 - dispensers 15, 16
 - hot and cold water 16
 - kitchen 16
 - mirrors 16
 - splash protection 16
- Heat lamps, shielding 24
- Hot air hand dryers 15
- Hot water heater
 - capacity 21
 - near dish washing machine 22
 - over utility sink 18
- Hot water sanitizing booster heater 22
- I**
- Ice
 - cold plates 7
 - for rapid chill 13
 - machine drain 19
- Ice cream dipper well 7
- Illinois State Plumbing Code 17, 19, 20
- Indirect wastes 19
- Insect control 14, 30
- Inspections 5
- J**
- Janitorial sinks 14, 18, 21
- Janitorial station, area finishes 25
- Joists 25

- L**
- Laundry
 - bags 13
 - location, clothes dryer 24
- Lighting 23, 24, 35
- Liquid waste
 - from garbage 31
 - sewage 17
- Liquor storage 13
- Locker rooms, area finishes 26
- Lockers 15
- M**
- Maintenance equipment storage 14, 18
- Make-up air 34, 35
- Masonry 30
- Metering faucet 16
- Mirrors 16
- Mixing valve 16
- Monolithic floors 24
- Mop sinks 18, 25 (see also janitorial sinks)
- N**
- NSF 7, 9, 11, 14, 15, 22, 25, 32
- O**
- Opening inspections 5 (see also final inspections)
- Outdoor cooking 25
- P**
- Painted drywall
 - ceilings 28
 - walls 25
- Paints 28
- Pass-thru windows construction 9
- Peg board 14
- Permit approval 5
- Personal belongings 15
- Pest control
 - firewood 14
 - restrooms (fly control) 15
 - screened vents 30
 - solid masonry 30
- Pesticide storage 13

Plan review
 application 5, 17
 requirement 2
 ventilation, exhaust hood 32
Plumbing
 inspections 5
 requirements 2
Plumbing Code 17, 19, 20 (see Illinois State Plumbing Code)
Pop coolers 12 (see Beverage display coolers)
Portable 9, 12
Pot washing sinks indirect wastes 19
Pressure
 dish washing machine 23
 spray hoses 18
 backflow protection 19
 floor drains, water flushing 20
 ventilation hood 33, 35
 water at janitorial sink 18
Processing rooms, refrigerated 12, 20
Produce cooler doors, drains 20
Public access 15

R

Raised floor platforms 11
Refrigeration
 and freezers 11, 12, 20, 23
 indoor garbage rooms 32
 shelving 14
Refuse
 collection, outside storage 30
 containers in restrooms 15
Restroom
 area finishes 26, 29
 equipment, number 15
 lighting 23
Rice dipper well 7
Rodent control 30
RPZ for submerged inlets 18

S

Salad bar indirect waste 19
Sanitary containers in restrooms 15
Sanitary district
 dumpster area 31
 grease interceptors 17, 18
Sealing
 equipment installation 9, 11, 16
 floors, walls 26
 pest control 29

Self-closing
 faucet 16
 outside doors 30
 restroom doors 15
 service windows 9, 30
Self-service 11, 12 (see Customer service)
Server area finishes 26, 29
Sewage disposal 17
Sewer overhead lines 18
Shelving
 construction 14
 in refrigerators, freezers 15
 installation 13
Single service utensils 7
Sink
 drains 19
 food preparation 7
 hand washing 15, 16, 21
 janitorial, utility 14, 18, 21, 25
 manual utensil washing 20, 21
 pre-rinse 22
Slide channels pass-thru windows 9
Sneeze shields 8
Soda fountain sinks indirect wastes 19
Soiled dish table 21, 22
Spacing, equipment 9
Splash protection
 at hand washing sink 16
 equipment drains 19
 stored utensils 13
 wall finishes 25, 26, 28
Steam table indirect waste 19
Steam, ventilation 22, 32
Storage
 above walk-in units 11
 area finishes 24
 area lighting 23
 beverages 13
 chemicals 13
 dry storage 13
 estimating dry storage 2, 13
 for air-drying utensils 22
 hot water 21
 linen 13
 maintenance equipment 14
 mops, buckets 18
 outside garbage 30
 refrigeration, freezer 11, 12, 20
 shelving 14
 splash protection 16
 under sewer lines 18
Studs, support structures 25
Submerged inlet backflow protection 18

T

Table of area finishes 29
Table-mounted equipment 9
Temperature
 dish washing machine 22, 23
 food display equipment 8
refrigerator, freezer 11
Thermometers
 dish washing machine 22, 23
 final rinse 22, 23
 in food units 9
 location in coolers 11
Threaded water faucets 18
Threshold sweep 30
Tiled curb 18
Toilets
 number 15
 submerged inlets 18

U

Urinals
 number 15
 submerged inlets 18
Utensil
 area finishes 25, 29
 area lighting 23, 24
 sink 16, 18, 19, 20, 21
 storage 13, 15
 washing (mechanical) 22
Utility
 connections 9
 lines 11
 sink 21

V

Vacuum breakers
 submerged inlets 18
 toilets, urinals 15
Ventilation
 dish washing machine 22
 exhaust hood 8, 32, 35
 plans 5
 restrooms 15
Vents
 atmospheric 18
 screened 30

W

- Walk-In refrigeration
 - area finishes 25, 29
 - beer kegs, flooring 28
 - beverage storage 13
 - floor drains 20
 - indirect waste 19
 - lighting 23
 - space from ceiling 11
- Walk-up windows
 - construction 9
 - pest control 30
- Walls, area finishes 24, 25, 26, 27, 28, 29
- Water flushing of floors 20
- Water heater
 - near dish washer 21
 - near utility sink 18
- Water supply 17
- Wet mops 14
- Whipped butter dipper well 7
- Windows
 - drive-thru construction 9
 - pest control 30
- Worktables, refrigerated 12

Z

- Zoning requirements 2